



FAA  
Airports

Exhibit "C"

## Contract Provision Guidelines for Obligated Sponsors and Airport Improvement Program Projects

### BREACH OF CONTRACT TERMS

*This provision is required for all contracts that exceed the simplified acquisition threshold as stated in 2 CFR Part 200, Appendix II (A). This threshold is occasionally adjusted for inflation and is now equal to \$150,000.*

Any violation or breach of terms of this contract on the part of the Contractor or its subcontractors may result in the suspension or termination of this contract or such other action that may be necessary to enforce the rights of the parties of this agreement.

Owner will provide Contractor written notice that describes the nature of the breach and corrective actions the Contractor must undertake in order to avoid termination of the contract. Owner reserves the right to withhold payments to Contractor until such time the Contractor corrects the breach or the Owner elects to terminate the contract. The Owner's notice will identify a specific date by which the Contractor must correct the breach. Owner may proceed with termination of the contract if the Contractor fails to correct the breach by the deadline indicated in the Owner's notice.

The duties and obligations imposed by the Contract Documents and the rights and remedies available thereunder are in addition to, and not a limitation of, any duties, obligations, rights and remedies otherwise imposed or available by law.

---

## GENERAL CIVIL RIGHTS PROVISIONS

The Contractor agrees to comply with pertinent statutes, Executive Orders and such rules as are promulgated to ensure that no person shall, on the grounds of race, creed, color, national origin, sex, age, or disability be excluded from participating in any activity conducted with or benefiting from Federal assistance.

This provision binds the Contractor and subcontractors from the bid solicitation period through the completion of the contract. This provision is in addition to that required by Title VI of the Civil Rights Act of 1964.

### TITLE VI SOLICITATION NOTICE:

The City of Cleveland, in accordance with the provisions of Title VI of the Civil Rights Act of 1964 (78 Stat. 252, 42 USC §§ 2000d to 2000d-4) and the Regulations, hereby notifies all bidders or offerors that it will affirmatively ensure that any contract entered into pursuant to this advertisement, disadvantaged business enterprises (or airport concession disadvantaged business enterprises if this Agreement is a Concessions Agreement) will be afforded full and fair opportunity to submit bids in response to this invitation and will not be discriminated against on the grounds of race, color, or national origin in consideration for an award.

### COMPLIANCE WITH NONDISCRIMINATION REQUIREMENTS:

During the performance of this contract, the Contractor, for itself, its assignees, and successors in interest (hereinafter referred to as the "Contractor"), agrees as follows:

1. **Compliance with Regulations:** The Contractor (hereinafter includes consultants) will comply with the Title VI List of Pertinent Nondiscrimination Acts and Authorities, as they may be amended from time to time, which are herein incorporated by reference and made a part of this contract.
2. **Nondiscrimination:** The Contractor, with regard to the work performed by it during the contract, will not discriminate on the grounds of race, color, or national origin in the selection and retention of subcontractors, including procurements of materials and leases of equipment. The Contractor will not participate directly or indirectly in the discrimination prohibited by the Nondiscrimination Acts and Authorities, including employment practices when the contract covers any activity, project, or program set forth in Appendix B of 49 CFR part 21.
3. **Solicitations for Subcontracts, including Procurements of Materials and Equipment:** In all solicitations, either by competitive bidding or negotiation made by the Contractor for work to be performed under a subcontract, including procurements of materials, or leases of equipment, each potential subcontractor or supplier will be notified by the Contractor of the contractor's obligations under this contract and the Nondiscrimination Acts and Authorities on the grounds of race, color, or national origin.
4. **Information and Reports:** The Contractor will provide all information and reports required by the Acts, the Regulations, and directives issued pursuant thereto and will permit access to its books, records, accounts, other sources of information, and its facilities as may be determined by the sponsor or the Federal Aviation Administration to be pertinent to ascertain compliance with such Nondiscrimination Acts and Authorities and instructions. Where any information required of a contractor is in the exclusive possession of another who fails or refuses to furnish the information, the Contractor will so certify to the sponsor or the Federal

---

Aviation Administration, as appropriate, and will set forth what efforts it has made to obtain the information.

5. **Sanctions for Noncompliance:** In the event of a Contractor's noncompliance with the non-discrimination provisions of this contract, the sponsor will impose such contract sanctions as it or the Federal Aviation Administration may determine to be appropriate, including, but not limited to:
  - a. Withholding payments to the Contractor under the contract until the Contractor complies; and/or
  - b. Cancelling, terminating, or suspending a contract, in whole or in part.
6. **Incorporation of Provisions:** The Contractor will include the provisions of paragraphs one through six in every subcontract, including procurements of materials and leases of equipment, unless exempt by the Acts, the Regulations, and directives issued pursuant thereto. The Contractor will take action with respect to any subcontract or procurement as the sponsor or the Federal Aviation Administration may direct as a means of enforcing such provisions including sanctions for noncompliance. Provided, that if the Contractor becomes involved in, or is threatened with litigation by a subcontractor, or supplier because of such direction, the Contractor may request the sponsor to enter into any litigation to protect the interests of the sponsor. In addition, the Contractor may request the United States to enter into the litigation to protect the interests of the United States.

#### TITLE VI LIST OF PERTINENT NONDISCRIMINATION ACTS AND AUTHORITIES

During the performance of this contract, the Contractor, for itself, its assignees, and successors in interest (hereinafter referred to as the "Contractor") agrees to comply with the following non-discrimination statutes and authorities; including but not limited to:

- Title VI of the Civil Rights Act of 1964 (42 USC § 2000d *et seq.*, 78 stat. 252) (prohibits discrimination on the basis of race, color, national origin);
- 49 CFR part 21 (Non-discrimination in Federally-assisted programs of the Department of Transportation—Effectuation of Title VI of the Civil Rights Act of 1964);
- The Uniform Relocation Assistance and Real Property Acquisition Policies Act of 1970, (42 USC § 4601) (prohibits unfair treatment of persons displaced or whose property has been acquired because of Federal or Federal-aid programs and projects);
- Section 504 of the Rehabilitation Act of 1973 (29 USC § 794 *et seq.*), as amended (prohibits discrimination on the basis of disability); and 49 CFR part 27;
- The Age Discrimination Act of 1975, as amended (42 USC § 6101 *et seq.*) (prohibits discrimination on the basis of age);
- Airport and Airway Improvement Act of 1982 (49 USC § 471, Section 47123), as amended (prohibits discrimination based on race, creed, color, national origin, or sex);
- The Civil Rights Restoration Act of 1987 (PL 100-209) (broadened the scope, coverage and applicability of Title VI of the Civil Rights Act of 1964, the Age Discrimination Act of 1975 and Section 504 of the Rehabilitation Act of 1973, by expanding the definition of the terms "programs or activities" to include all of the programs or activities of the Federal-aid recipients, sub-recipients and contractors, whether such programs or activities are Federally funded or not);
- Titles II and III of the Americans with Disabilities Act of 1990, which prohibit discrimination on the basis of disability in the operation of public entities, public and private transportation systems,

---

places of public accommodation, and certain testing entities (42 USC §§ 12131 – 12189) as implemented by U.S. Department of Transportation regulations at 49 CFR parts 37 and 38;

- The Federal Aviation Administration's Nondiscrimination statute (49 USC § 47123) (prohibits discrimination on the basis of race, color, national origin, and sex);
- Executive Order 12898, Federal Actions to Address Environmental Justice in Minority Populations and Low-Income Populations, which ensures nondiscrimination against minority populations by discouraging programs, policies, and activities with disproportionately high and adverse human health or environmental effects on minority and low-income populations;
- Executive Order 13166, Improving Access to Services for Persons with Limited English Proficiency, and resulting agency guidance, national origin discrimination includes discrimination because of limited English proficiency (LEP). To ensure compliance with Title VI, you must take reasonable steps to ensure that LEP persons have meaningful access to your programs (70 Fed. Reg. at 74087 to 74100);
- Title IX of the Education Amendments of 1972, as amended, which prohibits you from discriminating because of sex in education programs or activities (20 USC 1681 et seq).

#### CLEAN AIR AND WATER POLLUTION CONTROL

*This provision is required if the Agreement and lower tier contracts exceed \$150,000.*

Contractor agrees to comply with all applicable standards, orders, and regulations issued pursuant to the Clean Air Act (42 USC § 740-7671q) and the Federal Water Pollution Control Act as amended (33 USC § 1251-1387). The Contractor agrees to report any violation to the Owner immediately upon discovery. The Owner assumes responsibility for notifying the Environmental Protection Agency (EPA) and the Federal Aviation Administration.

Contractor must include this requirement in all subcontracts that exceeds \$150,000.

#### CONTRACT WORKHOURS AND SAFETY STANDARDS ACT REQUIREMENTS

*This provision applies if the Agreement exceeds \$100,000 and employs laborers, mechanics, watchmen, and guards. This includes members of survey crews and exploratory drilling operations.*

##### 1. Overtime Requirements.

No contractor or subcontractor contracting for any part of the contract work which may require or involve the employment of laborers or mechanics shall require or permit any such laborer or mechanic, including watchmen and guards, in any workweek in which he or she is employed on such work to work in excess of forty hours in such workweek unless such laborer or mechanic receives compensation at a rate not less than one and one-half times the basic rate of pay for all hours worked in excess of forty hours in such workweek.

##### 2. Violation; Liability for Unpaid Wages; Liquidated Damages.

In the event of any violation of the clause set forth in paragraph (1) of this clause, the Contractor and any subcontractor responsible therefor shall be liable for the unpaid wages. In addition, such contractor and subcontractor shall be liable to the United States (in the case of work done under contract for the District of Columbia or a territory, to such District or to such territory), for liquidated damages. Such liquidated damages shall be computed with respect to each individual laborer or mechanic, including watchmen and guards, employed in violation of the clause set forth in paragraph (1) of this clause, in the

---

sum of \$10 for each calendar day on which such individual was required or permitted to work in excess of the standard workweek of forty hours without payment of the overtime wages required by the clause set forth in paragraph (1) of this clause.

### 3. Withholding for Unpaid Wages and Liquidated Damages.

The Federal Aviation Administration (FAA) or the Owner shall upon its own action or upon written request of an authorized representative of the Department of Labor withhold or cause to be withheld, from any moneys payable on account of work performed by the contractor or subcontractor under any such contract or any other Federal contract with the same prime contractor, or any other federally assisted contract subject to the Contract Work Hours and Safety Standards Act, which is held by the same prime contractor, such sums as may be determined to be necessary to satisfy any liabilities of such contractor or subcontractor for unpaid wages and liquidated damages as provided in the clause set forth in paragraph (2) of this clause.

### 4. Subcontractors.

The Contractor or subcontractor shall insert in any subcontracts the clauses set forth in paragraphs (1) through (4) and also a clause requiring the subcontractor to include these clauses in any lower tier subcontracts. The prime contractor shall be responsible for compliance by any subcontractor or lower tier subcontractor with the clauses set forth in paragraphs (1) through (4) of this clause.

## **DISADVANTAGED BUSINESS ENTERPRISE**

### Information Submitted as a matter of bidder responsiveness:

The Owner's award of this contract is conditioned upon Bidder or Offeror satisfying the good faith effort requirements of 49 CFR §26.53.

As a condition of bid responsiveness, the Bidder or Offeror must submit the following information with its proposal on the forms provided herein:

- 1) The names and addresses of Disadvantaged Business Enterprise (DBE) firms that will participate in the contract;
- 2) A description of the work that each DBE firm will perform;
- 3) The dollar amount of the participation of each DBE firm listed under (1)
- 4) Written statement from Bidder or Offeror that attests their commitment to use the DBE firm(s) listed under (1) to meet the Owner's project goal; and
- 5) If Bidder or Offeror cannot meet the advertised project DBE goal, evidence of good faith efforts undertaken by the Bidder or Offeror as described in appendix A to 49 CFR part 26.

### Information submitted as a matter of bidder responsibility:

The Owner's award of this contract is conditioned upon Bidder or Offeror satisfying the good faith effort requirements of 49 CFR §26.53.

The successful Bidder or Offeror must provide written confirmation of participation from each of the DBE firms the Bidder or Offeror lists in its commitment within five days after bid opening.

- 1) The names and addresses of Disadvantaged Business Enterprise (DBE) firms that will participate in the contract;
- 2) A description of the work that each DBE firm will perform;



- 
- 3) The dollar amount of the participation of each DBE firm listed under (1)
  - 4) Written statement from Bidder or Offeror that attests their commitment to use the DBE firm(s) listed under (1) to meet the Owner's project goal; and
  - 5) If Bidder or Offeror cannot meet the advertised project DBE goal, evidence of good faith efforts undertaken by the Bidder or Offeror as described in appendix A to 49 CFR part 26.

#### **SOLICITATION LANGUAGE (RACE/GENDER NEUTRAL MEANS)**

The requirements of 49 CFR part 26 apply to this contract. It is the policy of the Department of Port Control to practice nondiscrimination based on race, color, sex, or national origin in the award or performance of this contract. The Owner encourages participation by all firms qualifying under this solicitation regardless of business size or ownership.

#### **DISADVANTAGED BUSINESS ENTERPRISES**

##### **Contract Assurance (§ 26.13) –**

The Contractor or subcontractor shall not discriminate on the basis of race, color, national origin, or sex in the performance of this contract. The Contractor shall carry out applicable requirements of 49 CFR part 26 in the award and administration of Department of Transportation-assisted contracts. Failure by the Contractor to carry out these requirements is a material breach of this contract, which may result in the termination of this contract or such other remedy as the Owner deems appropriate, which may include, but is not limited to:

- 1) Withholding monthly progress payments;
- 2) Assessing sanctions;
- 3) Liquidated damages; and/or
- 4) Disqualifying the Contractor from future bidding as non-responsible.

**Prompt Payment (§26.29) –** The prime contractor agrees to pay each subcontractor under this prime contract for satisfactory performance of its contract no later than 10 days from the receipt of each payment the prime contractor receives from the Department of Port Control. The prime contractor agrees further to return retainage payments to each subcontractor within 10 days after the subcontractor's work is satisfactorily completed. Any delay or postponement of payment from the above referenced time frame may occur only for good cause following written approval of the Department of Port Control. This clause applies to both DBE and non-DBE subcontractors. Failure to comply with these prompt payment requirements is a breach of the Contract, which may lead to any remedies permitted under law, including, but not limited to Contractor debarment.

#### **EQUAL OPPORTUNITY CLAUSE**

*This section applies if the dollar amount of the Agreement exceeds \$10,000.*

During the performance of this contract, the Contractor agrees as follows:

- (1) The Contractor will not discriminate against any employee or applicant for employment because of race, color, religion, sex, or national origin. The Contractor will take affirmative action to ensure that applicants are employed, and that employees are treated during employment, without regard to their race, color, religion, sex, sexual orientation, gender identify, or national origin. Such action shall

---

include, but not be limited to, the following: employment, upgrading, demotion, or transfer; recruitment or recruitment advertising; layoff, or termination; rates of pay or other forms of compensation; and selection for training, including apprenticeship. The Contractor agrees to post in conspicuous places, available to employees and applicants for employment, notices to be provided setting forth the provisions of this nondiscrimination clause.

(2) The Contractor will, in all solicitations or advertisements for employees placed by or on behalf of the Contractor, state that all qualified applicants will receive considerations for employment without regard to race, color, religion, sex, or national origin.

(3) The Contractor will send to each labor union or representative of workers with which it has a collective bargaining agreement or other contract or understanding, a notice to be provided advising the said labor union or workers' representatives of the Contractor's commitments under this section and shall post copies of the notice in conspicuous places available to employees and applicants for employment.

(4) The Contractor will comply with all provisions of Executive Order 11246 of September 24, 1965, and of the rules, regulations, and relevant orders of the Secretary of Labor.

(5) The Contractor will furnish all information and reports required by Executive Order 11246 of September 24, 1965, and by rules, regulations, and orders of the Secretary of Labor, or pursuant thereto, and will permit access to his books, records, and accounts by the administering agency and the Secretary of Labor for purposes of investigation to ascertain compliance with such rules, regulations, and orders.

(6) In the event of the Contractor's noncompliance with the nondiscrimination clauses of this contract or with any of the said rules, regulations, or orders, this contract may be canceled, terminated, or suspended in whole or in part and the Contractor may be declared ineligible for further Government contracts or federally assisted construction contracts in accordance with procedures authorized in Executive Order 11246 of September 24, 1965, and such other sanctions may be imposed and remedies invoked as provided in Executive Order 11246 of September 24, 1965, or by rule, regulation, or order of the Secretary of Labor, or as otherwise provided by law.

(7) The Contractor will include the portion of the sentence immediately preceding paragraph (1) and the provisions of paragraphs (1) through (7) in every subcontract or purchase order unless exempted by rules, regulations, or orders of the Secretary of Labor issued pursuant to section 204 of Executive Order 11246 of September 24, 1965, so that such provisions will be binding upon each subcontractor or vendor. The Contractor will take such action with respect to any subcontract or purchase order as the administering agency may direct as a means of enforcing such provisions, including sanctions for noncompliance: *Provided, however*, that in the event a contractor becomes involved in, or is threatened with, litigation with a subcontractor or vendor as a result of such direction by the administering agency the Contractor may request the United States to enter into such litigation to protect the interests of the United States.

**FEDERAL FAIR LABOR STANDARDS ACT (FEDERAL MINIMUM WAGE)  
SOLICITATION CLAUSE**

All contracts and subcontracts that result from this solicitation incorporate by reference the provisions of 29 CFR part 201, the Federal Fair Labor Standards Act (FLSA), with the same force and effect as if

---

given in full text. The FLSA sets minimum wage, overtime pay, recordkeeping, and child labor standards for full and part-time workers.

The Contractor has full responsibility to monitor compliance to the referenced statute or regulation. The Contractor must address any claims or disputes that arise from this requirement directly with the U.S. Department of Labor – Wage and Hour Division.

### **CERTIFICATION REGARDING LOBBYING**

*This section applies if the dollar amount of the Agreement exceeds \$100,000.*

The Bidder or Offeror certifies by signing and submitting this bid or proposal, to the best of his or her knowledge and belief, that:

- (1) No Federal appropriated funds have been paid or will be paid, by or on behalf of the Bidder or Offeror, to any person for influencing or attempting to influence an officer or employee of an agency, a Member of Congress, an officer or employee of Congress, or an employee of a Member of Congress in connection with the awarding of any Federal contract, the making of any Federal grant, the making of any Federal loan, the entering into of any cooperative agreement, and the extension, continuation, renewal, amendment, or modification of any Federal contract, grant, loan, or cooperative agreement.
- (2) If any funds other than Federal appropriated funds have been paid or will be paid to any person for influencing or attempting to influence an officer or employee of any agency, a Member of Congress, an officer or employee of Congress, or an employee of a Member of Congress in connection with this Federal contract, grant, loan, or cooperative agreement, the undersigned shall complete and submit Standard Form-LLL, "Disclosure Form to Report Lobbying," in accordance with its instructions.
- (3) The undersigned shall require that the language of this certification be included in the award documents for all sub-awards at all tiers (including subcontracts, subgrants, and contracts under grants, loans, and cooperative agreements) and that all sub-recipients shall certify and disclose accordingly.

This certification is a material representation of fact upon which reliance was placed when this transaction was made or entered into. Submission of this certification is a prerequisite for making or entering into this transaction imposed by section 1352, title 31, U.S. Code. Any person who fails to file the required certification shall be subject to a civil penalty of not less than \$10,000 and not more than \$100,000 for each such failure.

### **PROHIBITION OF SEGREGATED FACILITIES**

*This section applies if the Agreement includes tasks that qualify as construction work as defined by 41 CFR part 60.*

- (a) The Contractor agrees that it does not and will not maintain or provide for its employees any segregated facilities at any of its establishments, and that it does not and will not permit its employees to perform their services at any location under its control where segregated facilities are maintained. The Contractor agrees that a breach of this clause is a violation of the Equal Employment Opportunity clause in this contract.



---

(b) "Segregated facilities," as used in this clause, means any waiting rooms, work areas, rest rooms and wash rooms, restaurants and other eating areas, time clocks, locker rooms and other storage or dressing areas, parking lots, drinking fountains, recreation or entertainment areas, transportation, and housing facilities provided for employees that are segregated by explicit directive or are in fact segregated on the basis of race, color, religion, sex, or national origin because of written or oral policies or employee custom. The term does not include separate or single-user rest rooms or necessary dressing or sleeping areas provided to assure privacy between the sexes.

(c) The Contractor shall include this clause in every subcontract and purchase order that is subject to the Equal Employment Opportunity clause of this contract.

---

## OCCUPATIONAL SAFETY AND HEALTH ACT OF 1970

All contracts and subcontracts that result from this solicitation incorporate by reference the requirements of 29 CFR Part 1910 with the same force and effect as if given in full text. The employer must provide a work environment that is free from recognized hazards that may cause death or serious physical harm to the employee. The employer retains full responsibility to monitor its compliance and their subcontractor's compliance with the applicable requirements of the Occupational Safety and Health Act of 1970 (20 CFR Part 1910). The employer must address any claims or disputes that pertain to a referenced requirement directly with the U.S. Department of Labor – Occupational Safety and Health Administration.

## PROCUREMENT OF RECOVERED MATERIALS

*This section applies if the Agreement involves the procurement of a product that exceeds \$10,000.*

Contractor and subcontractor agree to comply with Section 6002 of the Solid Waste Disposal Act, as amended by the Resource Conservation and Recovery Act, and the regulatory provisions of 40 CFR Part 247. In the performance of this contract and to the extent practicable, the Contractor and subcontractors are to use products containing the highest percentage of recovered materials for items designated by the Environmental Protection Agency (EPA) under 40 CFR Part 247 whenever:

- 1) The contract requires procurement of \$10,000 or more of a designated item during the fiscal year; or
- 2) The contractor has procured \$10,000 or more of a designated item using Federal funding during the previous fiscal year.

The list of EPA-designated items is available at [www.epa.gov/smm/comprehensive-procurement-guidelines-construction-products](http://www.epa.gov/smm/comprehensive-procurement-guidelines-construction-products).

Section 6002(e) establishes exceptions to the preference for recovery of EPA-designated products if the contractor can demonstrate the item is:

- a) Not reasonably available within a timeframe providing for compliance with the contract performance schedule;
- b) Fails to meet reasonable contract performance requirements; or
- c) Is only available at an unreasonable price.

## RIGHTS TO INVENTIONS

*This section applies if the Agreement is with a small business firm or nonprofit organization and includes the performance of experimental, developmental, or research work.*

Contracts or agreements that include the performance of experimental, developmental, or research work must provide for the rights of the Federal Government and the Owner in any resulting invention as established by 37 CFR part 401, Rights to Inventions Made by Non-profit Organizations and Small Business Firms under Government Grants, Contracts, and Cooperative Agreements. This contract incorporates by reference the patent and inventions rights as specified within 37 CFR §401.14. Contractor must include this requirement in all sub-tier contracts involving experimental, developmental, or research work.

---

## TERMINATION FOR CONVENIENCE (PROFESSIONAL SERVICES)

*This section applies if the dollar amount of the Agreement exceeds \$10,000.*

The Owner may, by written notice to the Consultant, terminate this Agreement for its convenience and without cause or default on the part of Consultant. Upon receipt of the notice of termination, except as explicitly directed by the Owner, the Contractor must immediately discontinue all services affected.

Upon termination of the Agreement, the Consultant must deliver to the Owner all data, surveys, models, drawings, specifications, reports, maps, photographs, estimates, summaries, and other documents and materials prepared by the Engineer under this contract, whether complete or partially complete.

Owner agrees to make just and equitable compensation to the Consultant for satisfactory work completed up through the date the Consultant receives the termination notice. Compensation will not include anticipated profit on non-performed services.

Owner further agrees to hold Consultant harmless for errors or omissions in documents that are incomplete as a result of the termination action under this clause.

## TERMINATION FOR DEFAULT (PROFESSIONAL SERVICES)

Either party may terminate this Agreement for cause if the other party fails to fulfill its obligations that are essential to the completion of the work per the terms and conditions of the Agreement. The party initiating the termination action must allow the breaching party an opportunity to dispute or cure the breach.

The terminating party must provide the breaching party [7] days advance written notice of its intent to terminate the Agreement. The notice must specify the nature and extent of the breach, the conditions necessary to cure the breach, and the effective date of the termination action. The rights and remedies in this clause are in addition to any other rights and remedies provided by law or under this agreement.

- a) **Termination by Owner:** The Owner may terminate this Agreement in whole or in part, for the failure of the Consultant to:
1. Perform the services within the time specified in this contract or by Owner approved extension;
  2. Make adequate progress so as to endanger satisfactory performance of the Project; or
  3. Fulfill the obligations of the Agreement that are essential to the completion of the Project.

Upon receipt of the notice of termination, the Consultant must immediately discontinue all services affected unless the notice directs otherwise. Upon termination of the Agreement, the Consultant must deliver to the Owner all data, surveys, models, drawings, specifications, reports, maps, photographs, estimates, summaries, and other documents and materials prepared by the Engineer under this contract, whether complete or partially complete.

Owner agrees to make just and equitable compensation to the Consultant for satisfactory work completed up through the date the Consultant receives the termination notice. Compensation will not include anticipated profit on non-performed services.

Owner further agrees to hold Consultant harmless for errors or omissions in documents that are incomplete as a result of the termination action under this clause.

---

If, after finalization of the termination action, the Owner determines the Consultant was not in default of the Agreement, the rights and obligations of the parties shall be the same as if the Owner issued the termination for the convenience of the Owner.

- b) **Termination by Consultant:** The Consultant may terminate this Agreement in whole or in part, if the Owner:
1. Defaults on its obligations under this Agreement;
  2. Fails to make payment to the Consultant in accordance with the terms of this Agreement;
  3. Suspends the Project for more than [180] days due to reasons beyond the control of the Consultant.

Upon receipt of a notice of termination from the Consultant, Owner agrees to cooperate with Consultant for the purpose of terminating the agreement or portion thereof, by mutual consent. If Owner and Consultant cannot reach mutual agreement on the termination settlement, the Consultant may, without prejudice to any rights and remedies it may have, proceed with terminating all or parts of this Agreement based upon the Owner's breach of the contract

In the event of termination due to Owner breach, the Engineer is entitled to invoice Owner and to receive full payment for all services performed or furnished in accordance with this Agreement and all justified reimbursable expenses incurred by the Consultant through the effective date of termination action. Owner agrees to hold Consultant harmless for errors or omissions in documents that are incomplete as a result of the termination action under this clause.

## **EXHIBIT D**

### **Department of Port Control Specifications**

For all work performed under the jurisdiction of the Department of Port Control, the technical specifications located through the below link must be followed. Any deviation to these specifications must be approved by Asset Management, in writing, before the performance of any work, bidding or qualifying.

<https://www.clevelandairport.com/about-us/business-cle/asset-management>



# Exhibit "E"

## Fee Table

|  | Description  | \$ Per Hour |
|--|--|-------------|
|  |  |             |
|  |  |             |
|  | See attached CLE/BKL Emergency Alert Notification System Diagrams - Exhibits "G"   |             |
|  | Provide an itemized list of suggested equipment and costs as part of the proposal  |             |
|  | Provide extended maintenance support services as part of the agreement including, but not limited to, each 1-year option as exercised under the contract terms for up to three additional years or until contract expiration.  |             |
|  | Provide costs for hourly rates for phone support and/or on-site support to include travel. Travel fees shall include transportation, onsite visits, visitations with staff, general and administrative costs. There shall be no hidden costs associated with this request. Full disclosure of nature and amount of all fees and charges is mandatory. The Department shall not be responsible for the reimbursement of any costs not specifically set forth in the firm's bid. In addition, the Department shall reserve the right to not accept any part or the bidder's entire fee schedule. |             |
|  |  |             |
|  |  |             |
|  |  |             |
|  |  |             |
|  |  |             |
|  |  |             |

**COMPANY NAME:**

**SIGNATURE:** \_\_\_\_\_

**DATE:** \_\_\_\_\_

# EXHIBIT "F"

## Security Questionnaire

| Response Code             | Definition   |
|---------------------------|--|
| Y = Yes                   | Requirement can be implemented "out of box" without customizations or modifications to the existing application  |
| N = No                    | Requirement will not be implemented  |
| Cu = Customization        | Requirement can be met by changing existing solution or through use of solution tools (NOTE: In Comments column, describe the customization and the estimated level of complexity – High, Medium, or Low)                                    |
| F = Future                | Requirement will be met by packaged solution currently under development, in Beta test, or not yet released (NOTE: In Comments column, indicate expected release date and any anticipated additional cost)                                   |
| 3 = 3 <sup>rd</sup> Party | Requirement will be met by 3 <sup>rd</sup> party solution package that is included in this proposal (NOTE: In Comments column, indicate name of proposed 3 <sup>rd</sup> party solution package and proposed interface/integration services) |
| Co = Configuration        | Requirement can be met through changes to setting of tables, switches, and rules without modification to source code (NOTE: In Comments, describe any changes to "out of box" workflow functionality)  |

| City of Cleveland Requirements  | Response to Requirements |   |    |   |   |    | Comments/Clarifications |
|---|--------------------------|---|----|---|---|----|-------------------------|
|   | Y                        | N | CU | F | 3 | CO |                         |
| <b>Application &amp; Interface Security</b>   |                          |   |    |   |   |    |                         |
| Do you use OWASP guidelines or another standard to build your application securely?   |                          |   |    |   |   |    |                         |
| Do you review your application for security vulnerabilities and address any issues prior to deployment?   |                          |   |    |   |   |    |                         |
| <b>Business Continuity Management &amp; Operational Resilience</b>  |                          |   |    |   |   |    |                         |
| Is physical protection against damage (e.g., natural causes, natural disasters, deliberate attacks) anticipated in your disaster recovery plan? |                          |   |    |   |   |    |                         |
| Do you test your backup or redundancy mechanisms at least annually?   |                          |   |    |   |   |    |                         |
| <b>Change Control &amp; Configuration Management</b>  |                          |   |    |   |   |    |                         |
| Are there procedures in place to triage and remedy reported bugs and security vulnerabilities?  |                          |   |    |   |   |    |                         |
| <b>Datacenter Security</b>  |                          |   |    |   |   |    |                         |

## EXHIBIT "F"

|  |  |  |  |  |  |  |  |
|--|--|--|--|--|--|--|--|
| Are physical security perimeters (e.g., fences, walls, gates, electronic surveillance, physical authentication mechanisms, reception desks and security patrols and/or alarms) implemented at the data center storing City data? |  |  |  |  |  |  |  |
| <b>Governance and Risk Management</b>  |  |  |  |  |  |  |  |
| Do you maintain an Information Security Management Program (ISMP)?   |  |  |  |  |  |  |  |
| Do you have a risk assessment process, performed at least annually, calculating the likelihood and impact of all identified risks?   |  |  |  |  |  |  |  |
| <b>Human Resources</b>   |  |  |  |  |  |  |  |
| Are systems in place to monitor for privacy breaches and notify City expeditiously if our data is exposed or compromised?  |  |  |  |  |  |  |  |
| Are all employees, contractors and third parties with access to data, systems, and networks, subject to background verification?   |  |  |  |  |  |  |  |
| Do you train your employees regarding their information security roles and responsibilities?   |  |  |  |  |  |  |  |
| Are all personnel required to sign NDA or Confidentiality Agreements as a condition of employment to protect customer/tenant information?  |  |  |  |  |  |  |  |
| Are personnel trained and provided with awareness programs at least once every 3 years?  |  |  |  |  |  |  |  |
| Are documented policies, procedures and guidelines in place to govern change in employment and/or termination?   |  |  |  |  |  |  |  |
| Do the above procedures and guidelines account for timely revocation of access and return of assets?   |  |  |  |  |  |  |  |
| Do you access and share City data/metadata?  |  |  |  |  |  |  |  |
| Do you allow tenants to opt out of having their data/metadata accessed via inspection technologies?  |  |  |  |  |  |  |  |
| <b>Identity &amp; Access Management</b>  |  |  |  |  |  |  |  |
| Do you restrict, log and monitor access to your information security management systems? (E.g., hypervisors, firewalls, vulnerability scanners, network sniffers, APIs, etc.)  |  |  |  |  |  |  |  |

## EXHIBIT "F"

|   |  |  |  |  |  |  |  |
|---|--|--|--|--|--|--|--|
| Do you monitor and log privileged access (administrator level) to information security management systems?  |  |  |  |  |  |  |  |
| Are controls in place to prevent unauthorized access to your application, program or object source code?  |  |  |  |  |  |  |  |
| Do you provide multi-failure disaster recovery capability?  |  |  |  |  |  |  |  |
| Do you have more than one provider for each service you depend on?  |  |  |  |  |  |  |  |
| Do you review entitlements for all system users and administrators at least annually?   |  |  |  |  |  |  |  |
| Do you revoke or modify access upon any change in status of employees, contractors, business partners or involved third parties (termination, transfer or contract end)?  |  |  |  |  |  |  |  |
| Do you support use of, or integration with, existing customer-based Single Sign On (SSO) solutions to your service?   |  |  |  |  |  |  |  |
| Do you support identity federation standards (SAML, SPML, WS-Federation, etc.) as a means of authenticating/authorizing users?  |  |  |  |  |  |  |  |
| Do you support password (minimum length of 10, age, history of greater than 25, complexity upper/lower/digit/symbol) and account lockout (lockout threshold 5 attempts, lockout duration 15 or greater) policy enforcement? |  |  |  |  |  |  |  |
| Do you allow tenants/customers to define password and account lockout policies for their accounts?  |  |  |  |  |  |  |  |
| Do you support the ability to force password changes upon first logon?  |  |  |  |  |  |  |  |
| Do you have mechanisms in place for unlocking accounts that have been locked out (e.g., self-service via email, defined challenge questions, manual unlock)?  |  |  |  |  |  |  |  |
| Are utilities that can manage virtualized partitions (e.g., shutdown, clone, etc.) appropriately restricted and monitored?  |  |  |  |  |  |  |  |
| Do you have a capability to detect and respond to attacks that target the virtual infrastructure directly (e.g., shimming, Blue Pill, Hyper jumping, etc.)?   |  |  |  |  |  |  |  |
| <b>Infrastructure &amp; Virtualization Security</b>   |  |  |  |  |  |  |  |

## EXHIBIT "F"

|  |  |  |  |  |  |  |
|--|--|--|--|--|--|--|
| Are file integrity (host) and network intrusion detection (IDS) tools implemented?   |  |  |  |  |  |  |
| Is physical and logical user access to audit logs restricted to authorized personnel?  |  |  |  |  |  |  |
| Are audit logs reviewed on a regular basis for security events (e.g., with automated tools)?   |  |  |  |  |  |  |
| Do you log and alert any changes made to virtual machine images regardless of their running state (e.g., dormant, off or running)?   |  |  |  |  |  |  |
| Do you use a synchronized time-service protocol (e.g., NTP) to ensure all systems have a common time reference?  |  |  |  |  |  |  |
| Do your system capacity requirements take into account current, projected and anticipated capacity needs for all systems?  |  |  |  |  |  |  |
| Are security vulnerability assessment tools or services virtualization aware?  |  |  |  |  |  |  |
| Do you regularly review allowed access/connectivity (e.g., firewall rules) between security domains/zones within the network?  |  |  |  |  |  |  |
| Are operating systems hardened to provide only the necessary ports, protocols and services to meet business needs?   |  |  |  |  |  |  |
| Do you logically and physically segregate production and non-production environments?  |  |  |  |  |  |  |
| Are wireless security settings enabled with strong encryption for authentication and transmission, replacing vendor default settings? (e.g., encryption keys, passwords, SNMP community strings) |  |  |  |  |  |  |
| Can you detect the presence of unauthorized (rogue) network devices and immediately disconnect them from the network?  |  |  |  |  |  |  |
| Do your network architecture diagrams clearly identify high-risk environments and data flows that may have legal compliance impacts?   |  |  |  |  |  |  |



## EXHIBIT "F"

|   |  |  |  |  |  |  |  |
|---|--|--|--|--|--|--|--|
| Do you implement technical measures and apply defense-in-depth techniques (e.g., deep packet analysis, traffic throttling and black-holing) for detection and timely response to network-based attacks associated with anomalous ingress or egress traffic patterns (e.g., MAC spoofing and ARP poisoning attacks) and/or distributed denial-of-service (DDoS) attacks? |  |  |  |  |  |  |  |
| <b>Mobile Security</b>  |  |  |  |  |  |  |  |
| Do you allow mobile devices (such as smartphone and tablets) to access your private networks?   |  |  |  |  |  |  |  |
| <b>Security Incident Management, E-Discovery &amp; Cloud Forensic</b>   |  |  |  |  |  |  |  |
| Do you maintain liaisons and points of contact with local authorities to contact immediately in the case of a serious attack or incident (e.g., DDoS or Ransomware)?  |  |  |  |  |  |  |  |
| Do you have a documented security incident response plan?   |  |  |  |  |  |  |  |
| Does your logging and monitoring framework allow isolation of an incident to specific tenants?  |  |  |  |  |  |  |  |
| <b>Supply Chain Management, Transparency and Accountability</b>   |  |  |  |  |  |  |  |
| Do you have cloud supply chain providers (i.e., SaaS sits on top of a PaaS or IaaS provided by a 3rd party)?  |  |  |  |  |  |  |  |
| Do you design and implement controls to mitigate and contain data security risks through proper separation of duties, role-based access, and least-privileged access for all personnel within your supply chain?  |  |  |  |  |  |  |  |
| Do you make security incident information available to all affected customers and providers periodically through electronic methods (e.g., portals)?  |  |  |  |  |  |  |  |
| Do you collect capacity and use data for all relevant components of your cloud service offering?  |  |  |  |  |  |  |  |
| Do you provide tenants with capacity planning and use reports?  |  |  |  |  |  |  |  |
| Do you perform annual internal assessments of conformance and effectiveness of your   |  |  |  |  |  |  |  |

## EXHIBIT "F"

|   |  |  |  |  |  |  |
|---|--|--|--|--|--|--|
| policies, procedures, and supporting measures and metrics?  |  |  |  |  |  |  |
| Do you select and monitor outsourced providers in compliance with laws in the country where the data is processed, stored and transmitted?  |  |  |  |  |  |  |
| Do you select and monitor outsourced providers in compliance with laws in the country where the data originates?  |  |  |  |  |  |  |
| Does legal counsel review all third-party agreements?   |  |  |  |  |  |  |
| Do third-party agreements include provision for the security and protection of information and assets?  |  |  |  |  |  |  |
| Do you provide the client with a list and copies of all sub-processing agreements and keep this updated?  |  |  |  |  |  |  |
| Do you review the risk management and governance processes of partners to account for risks inherited from other members of that partner's supply chain?  |  |  |  |  |  |  |
| Are policies and procedures established, and supporting business processes and technical measures implemented, for maintaining complete, accurate and relevant agreements (e.g., SLAs) between providers and customers (tenants)? |  |  |  |  |  |  |
| Do you have the ability to measure and address non-conformance of provisions and/or terms across the entire supply chain (upstream/downstream)?   |  |  |  |  |  |  |
| Can you manage service-level conflicts or inconsistencies resulting from disparate supplier relationships?  |  |  |  |  |  |  |
| Do you review all agreements, policies and processes at least annually?   |  |  |  |  |  |  |
| Do you assure reasonable information security across your information supply chain by performing an annual review?  |  |  |  |  |  |  |
| Does your annual review include all partners/third-party providers upon which your information supply chain depends?  |  |  |  |  |  |  |
| Do you permit tenants to perform independent vulnerability assessments?   |  |  |  |  |  |  |

## EXHIBIT "F"

|   |  |  |  |  |  |  |  |
|---|--|--|--|--|--|--|--|
| Do you have external third-party services conduct vulnerability scans and periodic penetration tests on your applications and networks? |  |  |  |  |  |  |  |
| <b>Threat and Vulnerability Management</b>  |  |  |  |  |  |  |  |
| Do you have anti-malware programs installed on all of your systems, with at least daily updates?  |  |  |  |  |  |  |  |
| Do you conduct vulnerability scans at least monthly?  |  |  |  |  |  |  |  |
| Do you conduct application-layer vulnerability scans at least semi-annually?  |  |  |  |  |  |  |  |
| Can you rapidly deploy patches across all of your computing devices, applications and systems?  |  |  |  |  |  |  |  |

EXHIBIT "G"

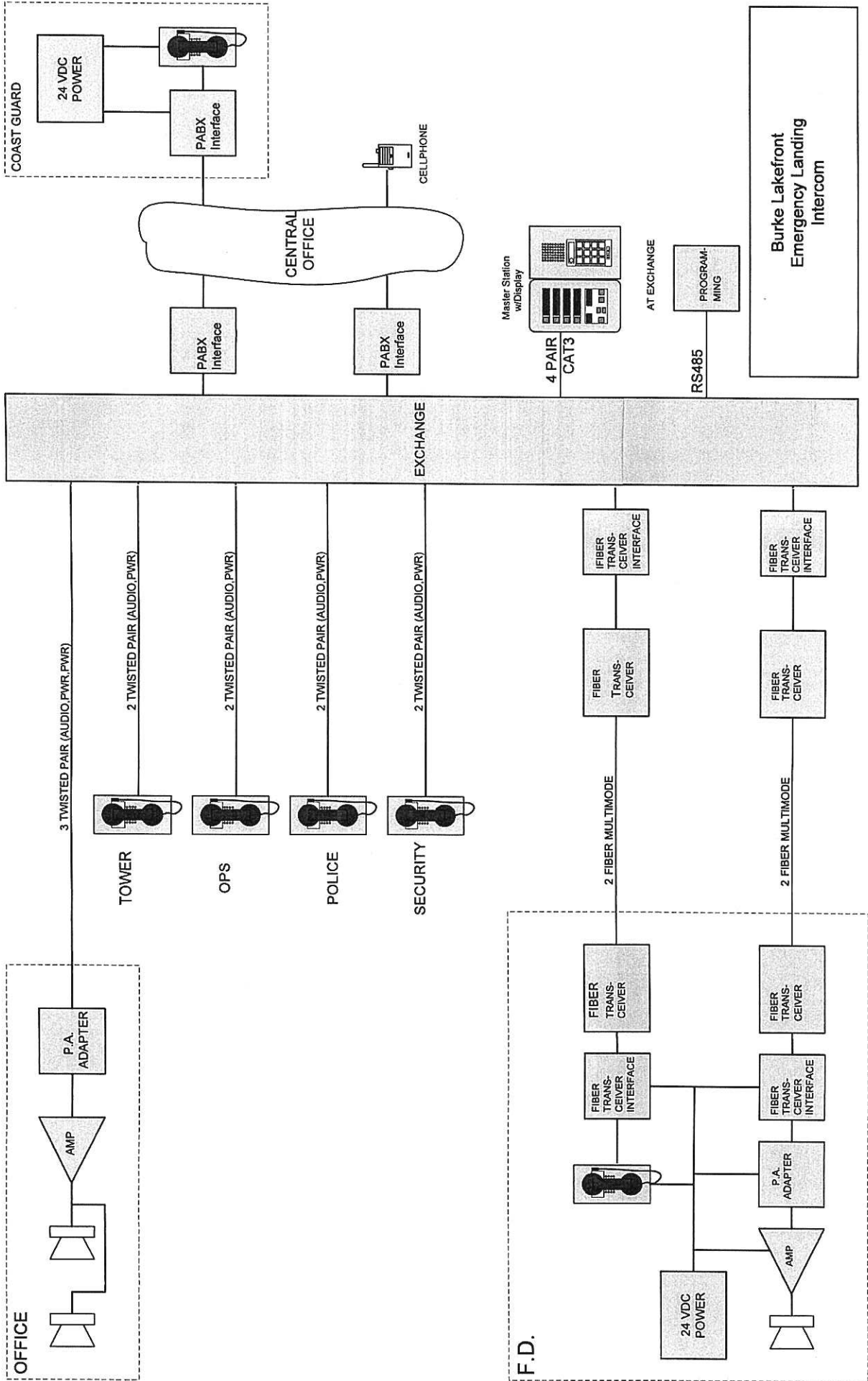

# Cleveland Hopkins Airport Crash Alert Riser

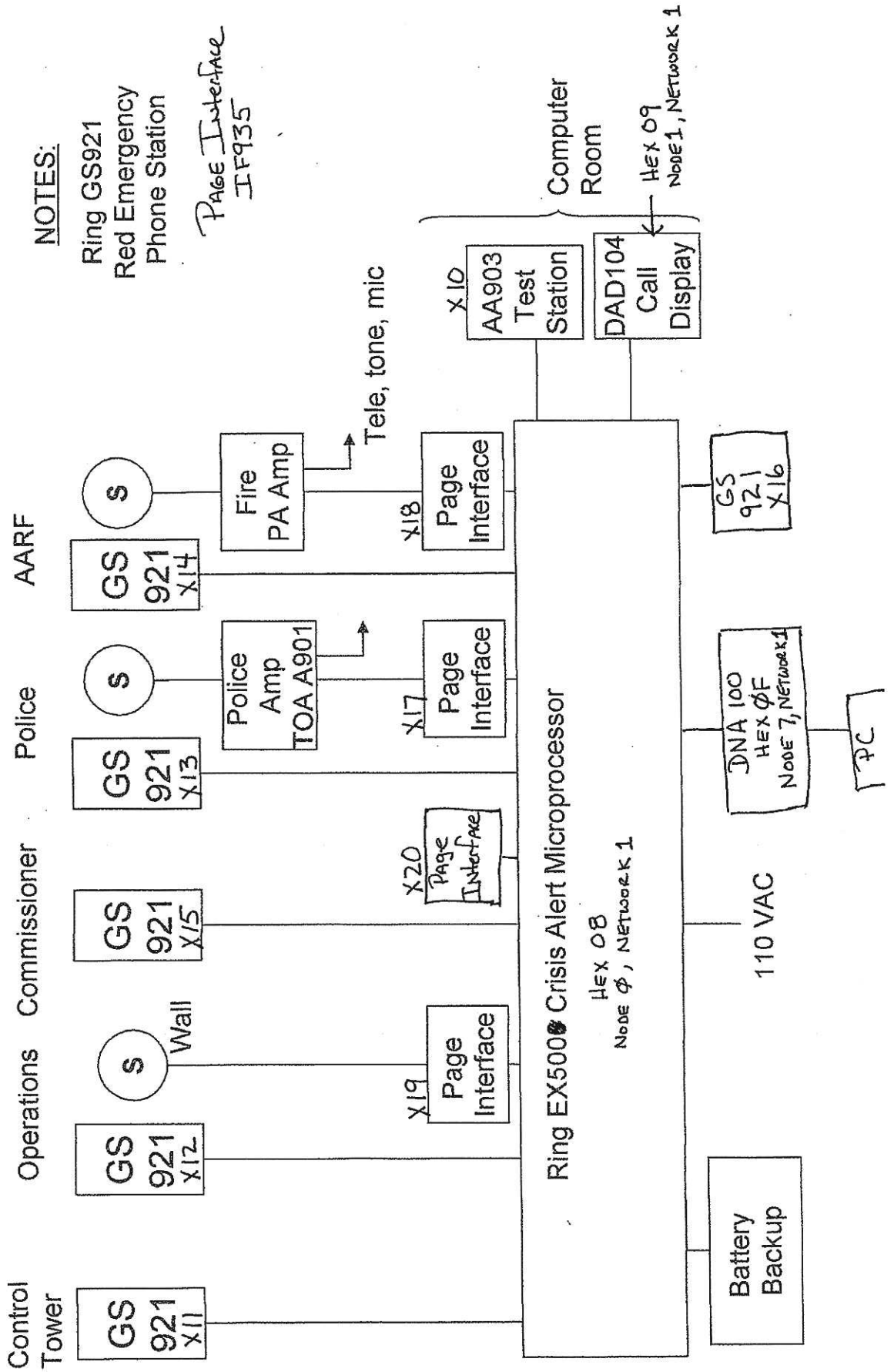

NOTES:

Ring GS921  
Red Emergency  
Phone Station

Page Interface  
IF935